

Body Trainer

Part Number 54466



SPECTRUM
Products[®]

7100 Spectrum Lane ~ Missoula, Montana 59808
800.791.8056 ~ www.spectrumproducts.com

54466 – Man Rev A

Table of Contents

Shipping Information:	3
Components and Hardware	4
Installation Overview	5
New Construction Anchor Installation	5
Existing Facility Anchor Installation	5
Assembly Instruction	6
Maintenance of Stainless Steel railings and equipment:	7

Shipping Information:

You have purchased a Spectrum Products Body Trainer. Providing the unit is installed correctly and properly maintained, it will furnish you with many years of trouble free use. It is important to read this entire manual prior to beginning assembly or operation.

Each unit will arrive partially assembled on one skid. Before accepting the unit from the carrier, inspect for visible damage and match the contents with those listed below. Spectrum is not responsible for lost or damaged freight.

The crate will contain all structural components and hardware. The following is a list of the components included with your shipment from Spectrum. Use **Error! Reference source not found.** on page 3 as a reference to identify each item listed below:

- 1 - Base
- 1 - Seat Support
- 1 - Seat

Components and Hardware



Installation Overview

Read all instructions before attempting to assemble or install the Body Trainer.

Pool Depth:

The Body Trainer is an adjustable unit with a maximum depth setting of 34 1/2" and a minimum setting of 22 1/2". Install unit in an area of the pool with at least a 36" water depth. This will allow the unit to be adjusted to suit the needs of multiple individuals.

Anchor Location/Installation:

The Body Trainer anchor centerline must be set back 18" from the pool wall, and 20" from centerline of anchor to centerline of anchor. Unit installed in two 1.50" I.D. anchors. See ANCHOR LAYOUT. diagram (shown below).

New Construction Anchor Installation

- Arrange 1.50" anchors as shown on the ANCHOR LAYOUT diagram. (18" from pool edge and 20" center to center) . It is recommended that anchors be located at least 6" from any expansion joint, crack, drain, or similar structure in the concrete deck.
- Locate a bonding source to bond (ground) the anchor. The steel rebar-bonding grid of the pool deck is the best choice for bonding the anchor. Attach a No. 8 solid copper wire (NEC Section 680-22) from the bonding bolt on the base of the anchor to the bonding grid.
- Secure anchor in place – proper height – anchor may be mudded in place. Set the anchor so that the finished top is 1/8" to 1/4" below finished deck level – allowing for anchor cap to be put in place when the unit is not in use.
- Use a level to insure the anchor is be vertically plumb.
- Place tape over the hole in the bottom of the anchor before pouring concrete deck – not allowing concrete to enter anchor opening.
- Pour concrete deck and finish. Allow the concrete to cure for at least 7-days before installing and using the unit.

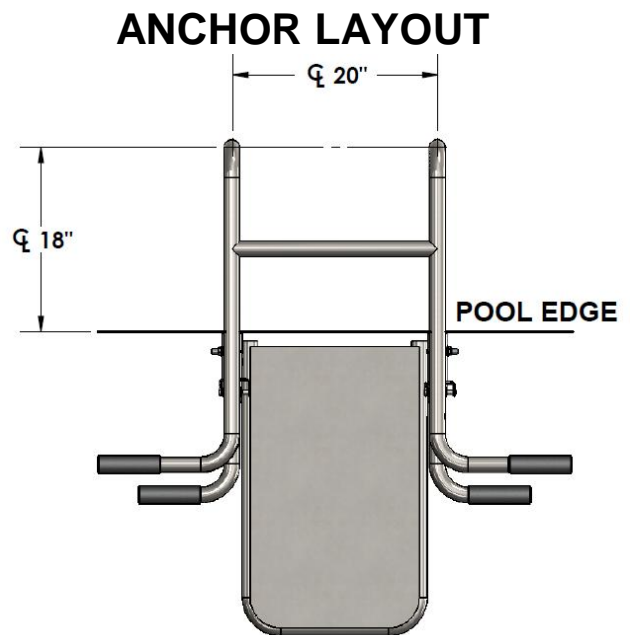

Existing Facility Anchor Installation

- Mark center locations of the anchors on the pool deck. Use the ANCHOR LAYOUT diagram for proper anchor configuration. It is recommended that anchors be located at least 6" from any expansion joint, crack, drain, or similar structure in the concrete deck..
- Core drill a 4" diameter hole at least 8" deep at each anchor location and remove any debris. Locate a bonding source to bond (ground) the anchor. The steel rebar-bonding grid of the pool deck is the best choice for bonding the anchor. Attach a No. 8 solid copper wire (NEC Section 680-22) from the bonding bolt on the base of the anchor to the bonding grid.

Note: *If the concrete deck is less than 8" thick, dig out the bottom of the hole to about 8" below the deck surface. If the concrete deck is 8" thick or more, an alternative anchor installation method may be used. In lieu of saw cutting the concrete deck, a concrete core drill may be employed to cut a 4" diameter hole at the desired anchor installation location. Epoxy or hydraulic cement may be used to secure the anchor in place. Make sure the anchor is properly bonded.*

- c. Place tape over the hole in the bottom of the anchor before pouring concrete – not allowing concrete to enter anchor opening.
- d. Fill the hole in the deck around the anchor with non-expanding concrete. Set the anchor so that the finished top is 1/8" to 1/4" below finished deck level – allowing for anchor cap to be put in place when the unit is not in use.
- e. Use a level, to level the anchor making sure that it is vertically plumb in all directions

Allow the concrete to cure for at least 7-days before installing and using the unit.

Assembly Instruction

The following tools will be required to complete the assembly of the lift:

- 3/4" ratchet or open-end wrench

Body Trainer Assembly

NOTE: All steps reference the exploded views on page 3.

1. Remove Seat Hinge from Aquasizer Seat Support by detaching 1/2" nut and washer.
2. Attach Seat to Seat Support using the Hinge previously removed. Tighten 1/2" hardware. *Note: Do not over tighten hardware. Doing so will pinch the seat and not allow it to move freely.*
3. Assemble Base to Seat support. Attach using (2) 3/8" Snap Pins.
4. Slide unit into anchors.

Maintenance of Stainless Steel railings and equipment:

Stainless Steel will discolor and eventually corrode if not properly maintained. Stainless steel is resistant to corrosion but environments of high moisture and temperature mixed with chlorine can lead to premature discoloration and or failure. With proper care and maintenance your product will last many years.

Maintenance to prevent rusting and corrosion:

When a corrosive environment is present, stainless steel must be maintained to prevent rusting of the surface. After installation, procedures must be put in place to regularly clean and re-passivate the surface. Chlorides will bond inter-granularly with the stainless steel and corrosion will begin. Daily rinsing with clean water is the best way to maintain the surface. This removes any chlorides that may have been splashed onto the surface in normal use. If ANY rust is seen during normal use it must be removed immediately. By using Spectra Clean System 1 it will remove the rust and re-passivate the surface.

Maintenance of stainless steel that has rusted severely:

Once the stainless steel has rusted to the degree where pitting of the surface has occurred, special precautions must be taken to protect the integrity of the steel. It is important to keep the rust removed from the surface as rust is self-propagating and will spread rapidly on and within the stainless steel. The first process is to remove the rust. Depending on the severity of the corrosion use either Spectra Clean System 2 or 3. If pitting of the surface has already occurred it is likely that the rust will continue to bleed out of the pits and come to the surface. Constant maintenance is necessary to make sure that the rust is removed as soon as possible after it is evident. Use of non-scratching Scotch-Brite® pads can help to remove rust.

Long term protection of the surface can be attained by applying Spectra Shield after removing the rust and drying the surface. This forms a protective layer in the pits and inter-granular boundaries that prevents air and water from entering the rusted spots. Without the air and water the rust cannot grow.

There are times other considerations require extra effort not discussed above. For clarification and assistance please call Spectrum Products Customer Care Line: 406.532.6343 or 1-800-791-8056 x.222