

BACKSTROKE START DEVICE

Part Number 143081

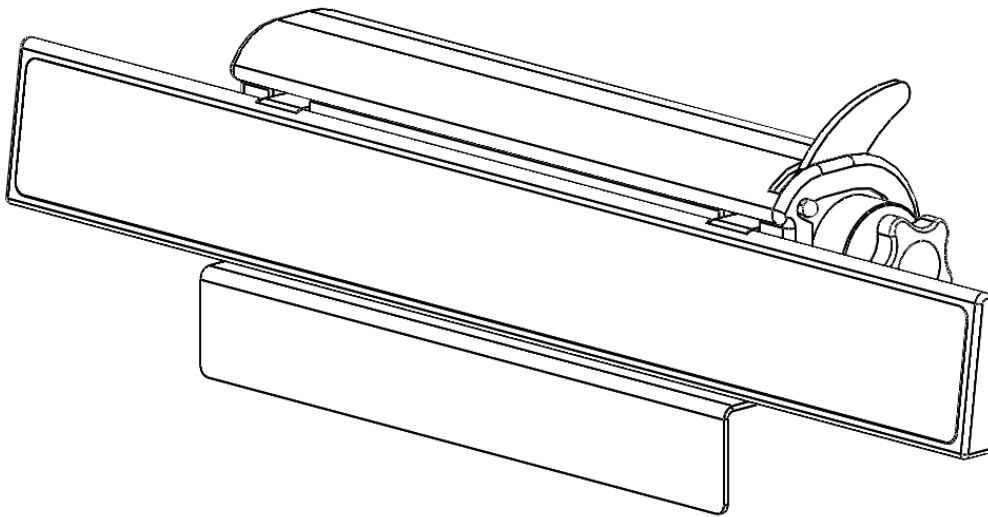

7100 Spectrum Lane | Missoula MT 59808 | 800.791.8056 | www.spectrumproducts.com
© 2014 EverActive Brands™

You have purchased a Spectrum Products Backstroke Start Device. Providing the unit is installed correctly and properly maintained, it will furnish you with many years of trouble free use. It is important to read this entire manual prior to beginning assembly or operation.

Shipping Information:

Each unit will arrive fully assembled in one box. Before accepting the package from the carrier, inspect for visible damage. Spectrum is not responsible for lost or damaged freight.

Components and Hardware

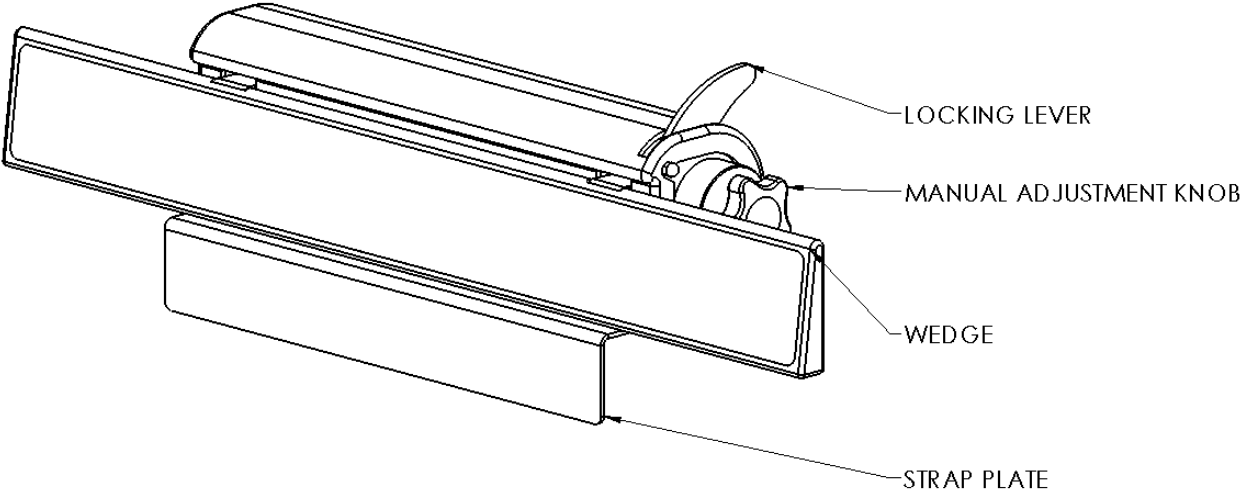

Installation Overview

Your new Backstroke Starting Device may be installed using any of the approved attachment methods provided by Spectrum Aquatics. Each unit is shipped with a strap attachment.

If you have not already done so, determine the correct attachment method for your pool and gutter style. Strap attachment is appropriate for recessed, trough, and haunch gutters, as shown below. Bull nose, rimflow and similar gutters require anchor mounting.

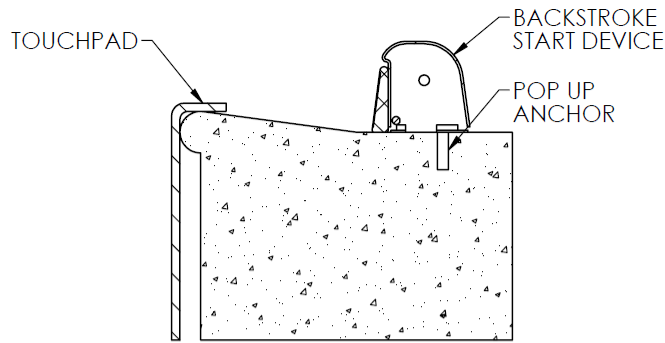

BULL NOSE COPING
*REQUIRES P/N 143061

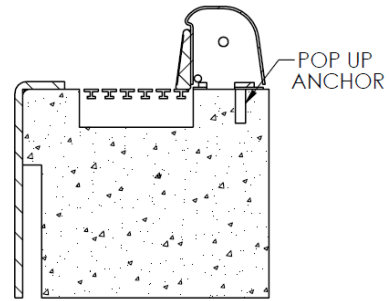

RIMFLOW GUTTER
*REQUIRES P/N 143061

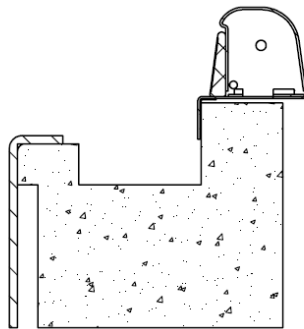

TROUGH GUTTER

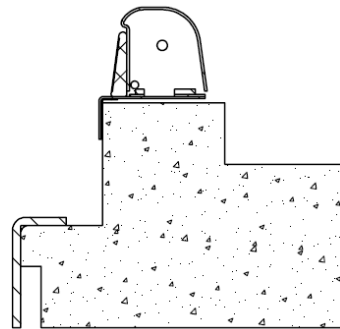

HAUNCH GUTTER

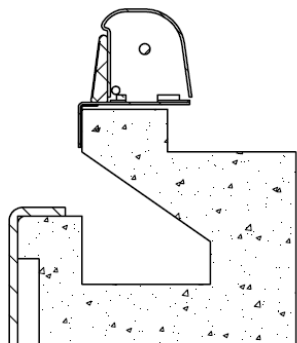

RECESSED GUTTER

In all cases, the installation must meet these conditions:

- Device should be centered in the swim lane.
- Device position must not pose a risk to swimmers.
- Device must be located so that it fully retracts out of the water and off of the touchpad.

Strapped Installation

To install your Backstroke Starting Device, first check your deck compatibility using the following guidelines.

- Strapped installation is designed to accommodate a single or dual post starting platform with a setback up to 36”.
- Device straps should be routed beneath or behind backstroke bars on the starting platform.

Once you have determined that the Backstroke Start Device is compatible with your deck and block configuration, the device can be attached. If the deck or starting block configuration does not allow for use of the standard strap attachment, please contact Spectrum Aquatics for alternate attachment options.

Attachment is completed by routing the straps behind the starting platform anchor posts and through the buckle as shown below.

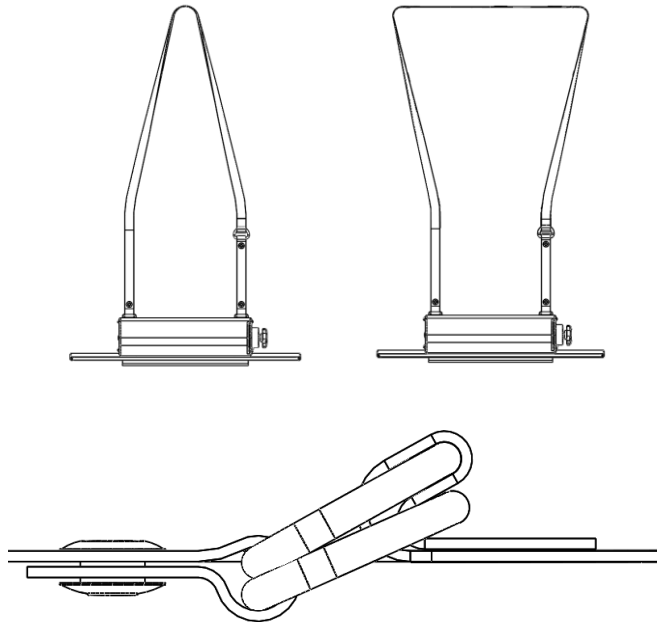

Pop Up Anchor Installation

The Backstroke Start Device can be anchored by a kit that permanently mounts into the deck but allows for convenient removal of the backstroke start device. (Kit Part # 143061).

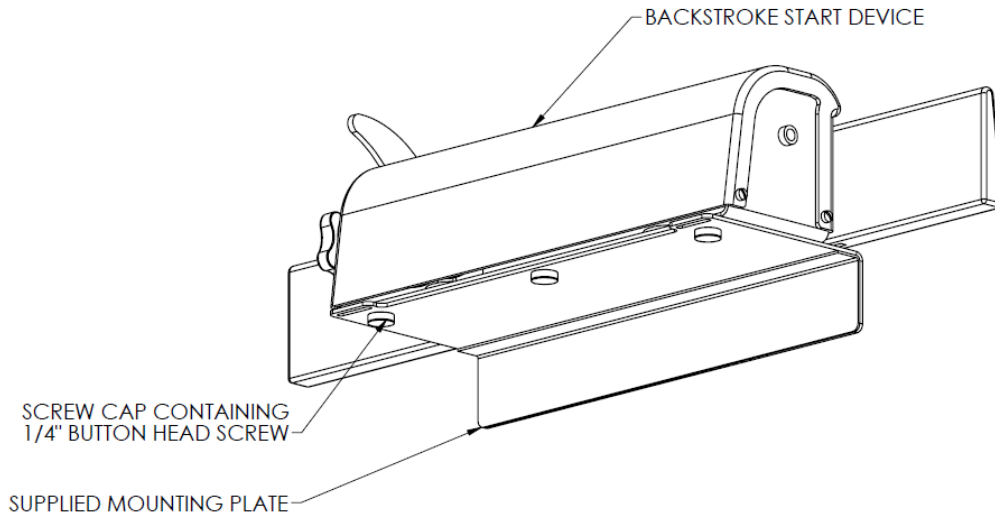

Remove the supplied mounting plate to expose the pop up anchor mounting slots (as shown below). For instructions on setting the pop up anchors in the deck, please refer to the installation manual that is included with the Pop up anchor kit (Part # 134061).

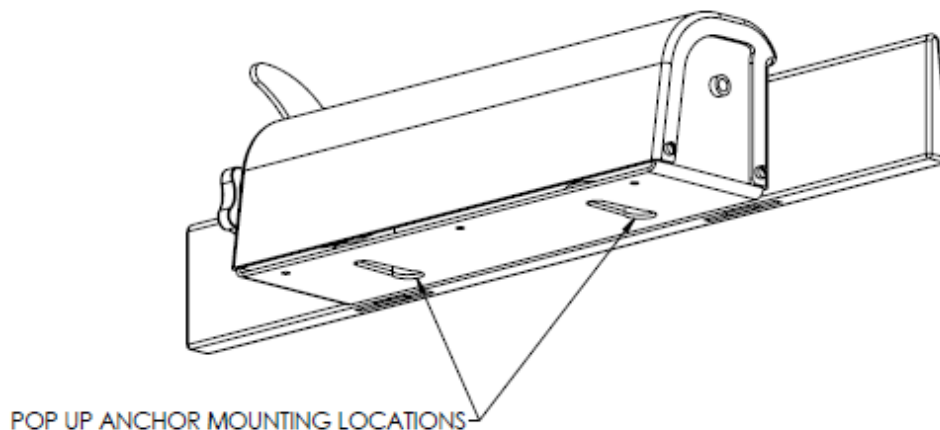

Other Approved Installations:

Custom mounts can be fabricated for the Backstroke Start Device. To obtain information on how to order a custom anchoring solution, or starting block integration, please contact your local distributor or Spectrum Aquatics 800.791.8056.

Operator's Guide

NOTE: The Backstroke Start Device should always be used in a manner consistent with the regulations set forth by the governing organization for the event.

The Backstroke Start Device is designed to be used by swimmers of all abilities unassisted from the pool. The procedure for use is described below.

Note: The first swimmer to use the Backstroke Start Device should submerge the wedge and wet the straps. This will help to prevent the likelihood of the straps retracting unevenly.

- Swimmer releases locking lever.

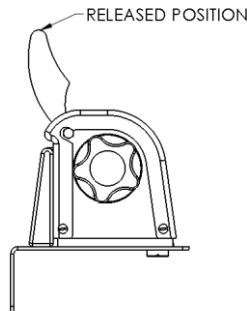

- Pull out wedge and position at the desired level on the wall.
- Hold wedge in place with feet and switch locking lever to locked position.

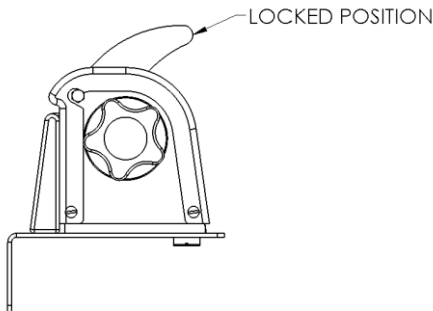

- Assume ready position and start at start signal.
- Wedge automatically retracts leaving the wall unobstructed for turns and finishes.
- Retracted wedge is ready for next swimmer.

Care and Maintenance

The following should be performed periodically to ensure safe and dependable use.

- Before storing for extended periods:
 - Remove unit from starting block
 - Release locking lever, fully extend wedge on straps to end of travel and use a weight to keep in place.
 - Rinse entire unit in **fresh** (not pool) water.
 - Allow unit to dry completely while extended. Once fully dry, hold wedge firmly, carefully remove weight and gradually allow wedge to retract.
 - Store in a clean, dry place.
- Remove any discoloration from stainless steel components with a 3M scratch pad (stainless steel components only). Wipe clean with a sponge dampened with Spectra Clean. Repeat these steps several times to passivate the stainless steel. Spectra Clean kits are available from Spectrum Aquatics. Do not spray with high-pressure water. Only clean with **fresh** (not pool) water.
- Case and wedge may be cleaned with **fresh** (not pool) water and a mild detergent.
- Inspect unit for damage or loosening connections.

Troubleshooting

Problem:	Cause:	Solution:
Wedge does not retract fully or retracts slowly	Temporary tension problem with spring Worn or damaged spring Wear or damage to shaft/bearings	During a race, wind the wedge back with the manual adjustment knob. If problem persists, contact Spectrum Aquatics Customer Service
Wedge does not retract evenly	Uneven strap tension while winding	Pull wedge to end of travel and allow to retract slowly

*Please contact your local distributor or Spectrum Customer Service to order parts 406.532.6321